

S P E C I F I C A T I O N
F O R
M A G N E T I C C A R D R E A D E R
(M a n u a l I n s e r t i o n t y p e)

Z U - 1 8 9 0 M

MAR . 2001

MATSUSHITA ELECTRIC INDUSTRIAL CO., LTD.

MATSUSHITA INDUSTRIAL EQUIPMENT CO., LTD.
OSAKA JAPAN

C O N T E N T S

1. INTRODUCTION-----	1
2. PRODUCT NAME -----	1
3. FUNCTION -----	1
4. EQUIPMENT SPECIFICATION -----	1
5. BASIC FEATURES-----	1
6. CARD SPECIFICATION-----	2
7. CIRCUIT CONSTRUCTION-----	3
8. ENVIRONMENTAL CHARACTERISTICS -----	5
9. UNIT LIFE AND RELIABILITY -----	6
10. GUARANTEE-----	6
11. MAINTENANCE-----	6
12. CAUTIONS ON THE USE -----	6
13. APPEARANCE-----	8

1. INTRODUCTION

This specification describes about manual insertion type magnetic card reader, featuring small size, lightweight and high performance, which enable to read card data, encoded by following ISO 1,2 standards.

2. PRODUCT NAME

- 2.1 Product Name : Manual insertion type magnetic card reader
- 2.2 Model No. : ZU-1890M

3. FUNCTION

- 3.1 Card operation : One way (Refer to Appearance)
- 3.2 Read/Write : Read only
- 3.3 Installation of the transport : Horizontal direction

4. EQUIPMENT SPECIFICATION

- 4.1 Out dimension : (W) 101.6 mm × (D) 112.6 mm × (H) 76.2 mm
- 4.2 Weight : Approximately 115 g
- 4.3 Supplied voltage
 - (1)Supplied voltage : DC 5 V (tolerance $\pm 10\%$) / Ripple (Less than 50 mV p-p)
 - (2)Current consumption : TYP. 20 mA, MAX. 25 mA
 - (3)Maximum applied voltage : DC 7 V
- 4.4 Connector : FFC-9TLAW2B(HONDA) Equivalent
- 4.5 Environment requirements : At indoor

5. BASIC FEATURES

- 5.1 Card operating speed : 10 cm/s ~ 120 cm/s
- 5.2 Magnetic head
 - (1)Numbers of channel : 2
 - (2)Core width : 1.4 mm
 - (3)Core material : Permalloy
- 5.3 Insulation resistance : More than 10 M at DC 250V
(Measured between P.C.B. ground terminal and frame)

6. CARD SPECIFICATION

6.1 Card standard

Materials and dimensions of the card should be submitted to ISO standards. But defined items in this specification are prior to these standards.

Card Standard	ISO 7810, ISO 7811	
	Track 1st	Track 2nd
Recording density	210 BPI	75 BPI
Recording capacity	79 Characters (7 bit code)	40 Characters (5 bit code)
Recording method	F2F	F2F

6.2 Location of tracks

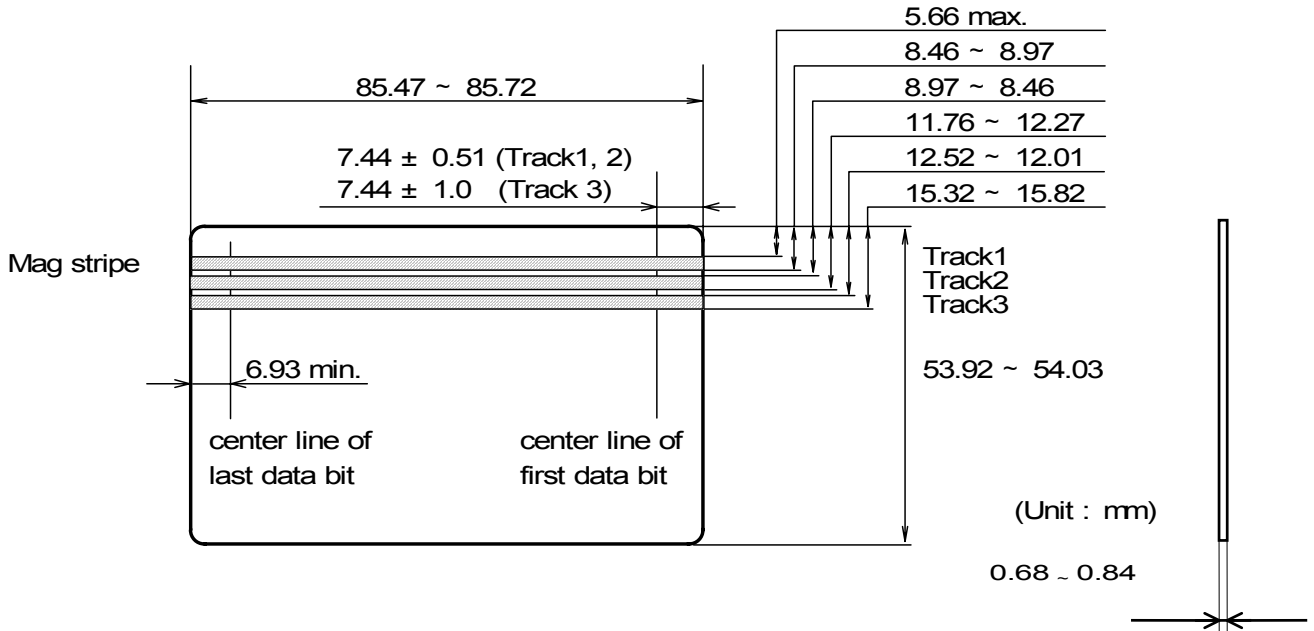

Figure 6.2 Location of Tracks

6.3 Physical characteristics

- (1) Thickness : 0.76 mm (tolerance ± 0.08 mm)
- (2) Transformation : 2.0 mm max.
- (3) Impermeability rate : More than 2.0
(Measured by light permeance desitometer)

6.4 Magnetic characteristics

- (1) Coercive force (Hc) : 2.4×10^4 A/m ~ 2.4×10^5 A/m
- (2) Residual flux (ϕr) : 1.25×10^{-8} Weber/cm (tolerance $\pm 0.15 \times 10^{-8}$ Weber/cm)
- (3) Square ratio ($\phi r / \phi m$) : More than 0.70

7. CIRCUIT CONSTRUCTION

7.1 Block diagram

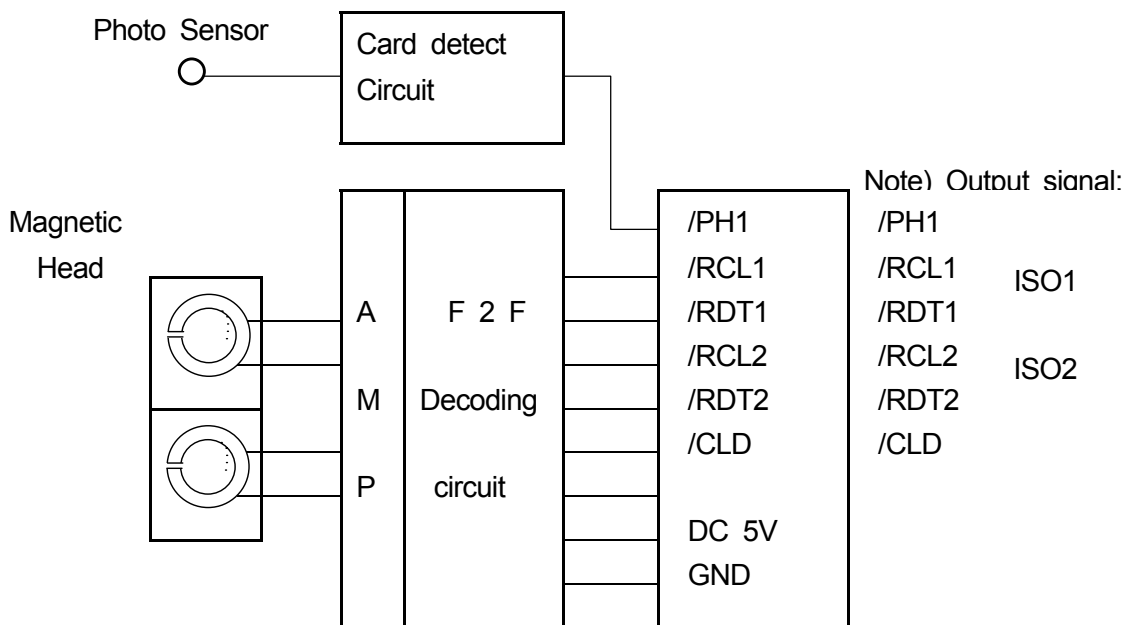

Fig 7.1 Block diagram

7.2 Interface requirement

- (1) Signal Level : CMOS level
- (2) Signal Logic : Low active
- (3) Connection condition

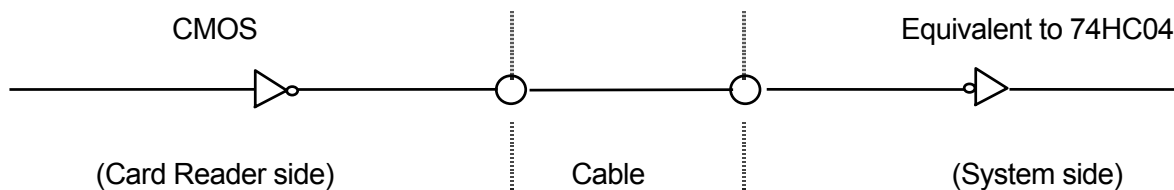

Fig 7.2 Connection of output circuit

- (4) Output voltage

Table 7.2 Output voltage

	Min(V)	Max(V)	Conditions
H level " 0 "	4.0	V _{CC}	I _{OH} = -1.0 mA
L level " 1 "	-	0.4	I _{OL} = +4.0 mA

7.3 Explanation of output signal

Output signals are /CLD, /RCL1,2, /RDT1,2, /PH1 and effective operation mode for each of these signals shall be "L" level for all.

- (1) /CLD (CARD LOAD) : The /CLD will be Low when a Magnetic Card is running in the Magnetic Card Reader.
The /CLD will be High when the Card is stopped or not present in the Card reader.
- (2) /RCL 1,2 (READ CLOCK) : This is used to sample the data line by its falling edges.
The time relationship of the clock with respect to the order signals is shown in Figure 7.4.
- (3) /RDT 1,2 (READ DATA) : At the moment /RCL change from High to Low; /RDT is " 1 " when the /RDT is Low , and /RDT is " 0 " when the /RDT is High.
- (4) /PH1 (SENSOR) : /PH1 will be Low when a Magnetic Card is inserted in the end of Magnetic Card Reader.

7.4 Output signal timing chart

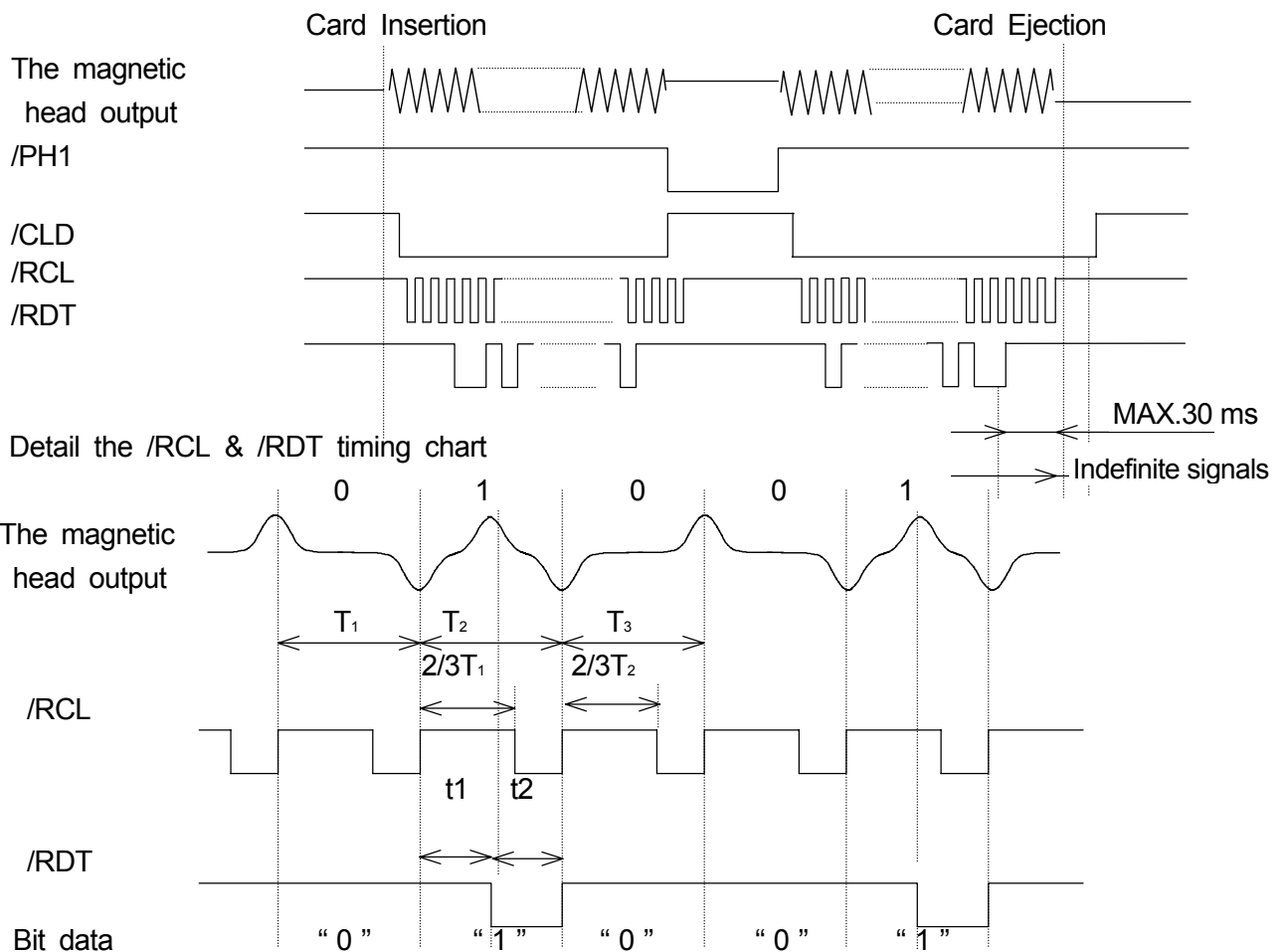

Fig 7.4.1 Timing Sequence

When the jitter of the magnetic head output is 0% , the following equation is satisfied.

$$T=T_1=T_2=T_3 , t_1=t_2$$

$$T (s) = \frac{2.54 \text{ cm/inch}}{\text{Recording density (BPI)}} \times \frac{1}{\text{Card speed(cm/s)}}$$

7.5 Terminal No. of connector

- (1) Maker : HONDA

- (2) Model No. Connector : FFC-9TLAW2B (Connect for PC. Board)
 Housing : HKP-9FS01 (Reference)
 Terminal : HKP-F413 (Reference)

- (3) Pin No. & Signal Name
 (Card reader side)

Connector Pin No.	Signal Name	Connector Pin No.	Signal Name
1	/PH1	7	GND
2	/RDT2	8	/RCL1
3	/CLD	9	/RDT1
4	/RCL2	10	----
5		11	----
6	DC 5 V		

Note) : Make sure to use the connection cable of less than 300 mm length for the card reader.

8. ENVIRONMENTAL CHARACTERISTICS

8.1 Operating Temperature Range : -20 °C ~ 60 °C

8.2 Operating Humidity Range : 10 % ~ 90 % RH (No condensation allowed)

8.3 Storage Temperature Range : -30 °C ~ 70 °C

8.4 Storage Humidity Range : 10 % ~ 95 % RH (No condensation allowed)
 (24 hours)

* Place the card reader in the standard environment (temperature: 20 °C ± 5 °C, humidity: 35 % to 60%RH). Leave it for 12 hours, and measure the functions. Make sure no abnormality is found.

8.5 Vibration : Vibration sweep 10 Hz/mm ~ 50 Hz/mm
 X, Y, Z directions

8.6 Shock durability : 294 m/s²(30 G)

8.7 Others : Make sure the source of noise that may deteriorate the characteristics of the card reader is not present around the card reader.

9. UNIT LIFE AND RELIABILITY

9.1 Life Magnetic head : 300,000 times pass

(conditions) In a clean office room.

In damp or dirty atmosphere, the life may be 1/3 to 1/5 of the above figure.

9.2 Error rate : Less than 0.1%

(conditions) This error rate is obtained when a new normal card (data "1010"···) is horizontally passed at the standard speed (30 cm/s ~ 60 cm/s) by manual operation in the clean environment at delivery from our company.

10. GUARANTEE

If defects should occur within one year after the delivery of the cardreader due to improper material or bad workmanship, the defective parts shall be replaced or repaired, free of charge.

11. MAINTENANCE

Because of difficulty at changing components on the P.C Board, replace of whole unit is recommended for service and maintenance.

12. CAUTIONS ON THE USE

Please be noted that we do not guarantee proper performance of the card reader if it is used other than the indicated specification range.

12.1 At the installation

- (1) Be sure to install on a flat surface so as to prevent any force to be applied to the card reader at the installation.
- (2) In the case that it is to incorporate into a machine, be sure not to touch any part of machine structures to the flexible P.C.B. other than the mounting surface.
Especially, electric noise on this area should be avoided not cause reading error.
- (3) Install it so as to run the card vertically to achieve most stable operation.
- (4) Installation of a card guide plate at the both (front and back) sides of the card running part may reinforce stability.
- (5) Do not touch the P.C.B. with bear hands.
- (6) Do not drop or bump anything against a card reader. Otherwise, failure may be the result.
- (7) The card reader should avoid installation of the following environment.
 - Watery, humid or dusty place.
 - Near machines which generate magnetic field or inducted noise.
(Printer, LED display, CRT etc.)
 - Place which gets direct sunlight.

12.2 At the use

- (1) Be sure to use a card, which conforms ISO standard.
Anti-magnetic of the applied card should be 2.4×10^4 A/m ~ 2.4×10^5 A/m of ISO standard.
- (2) Card operation speed should be within the specification range.
Forced stop or change of speed during the card operation may cause a read error.
Appropriate speed to maintain stable operation is 30 cm/s ~ 60 cm/s.
- (3) A slant insertion of a card causes poor contact of the card to the magnetic head, and which may result in a read error.
- (4) Store the card with caution to prevent dirt, scratch and distortion.
Especially no foreign matter shall be stuck on the magnetic stripe surface.
Use of such card may result in a read error.
- (5) Insert a cleaning card and clean the head periodically to prevent wearing of the magnetic head.
Head cleaning using the cleaning card should be performed about once a week if the room is not dusty.
- (6) Depends on installation environment (incorporation condition) or operation condition, external noise or electrostatics and so on may affect the machine, and which may cause an error or a wrong operation.
Check the level of noise resistance and electrostatic resistance of your factory before using the card reader.

13. APPEARANCE

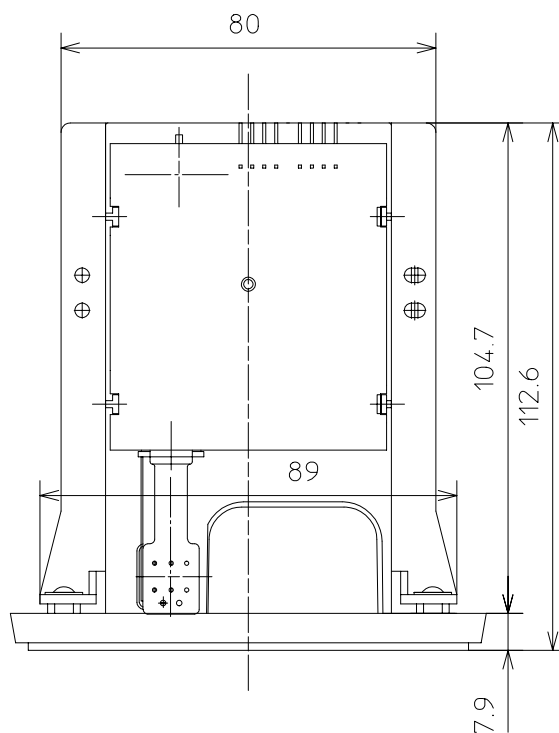
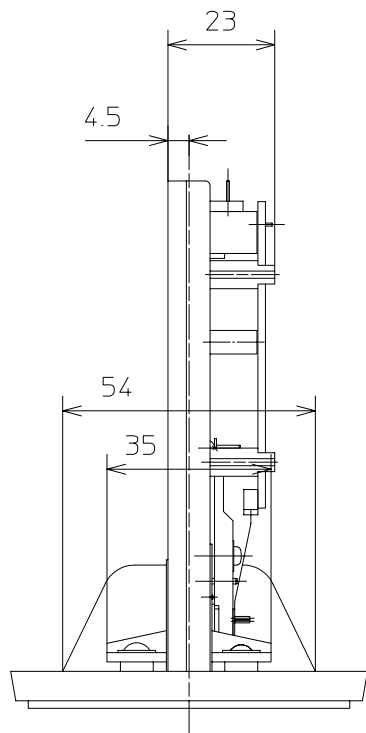

REAR view

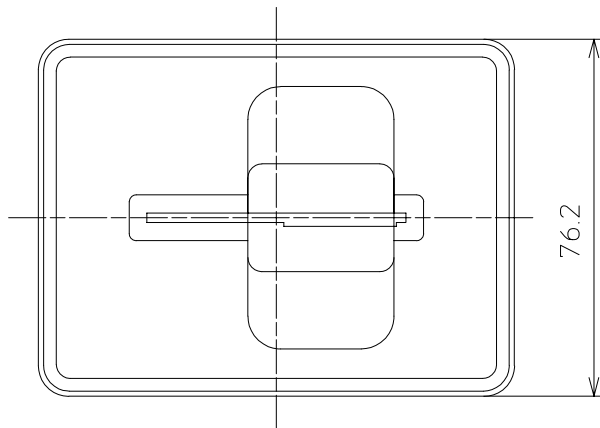
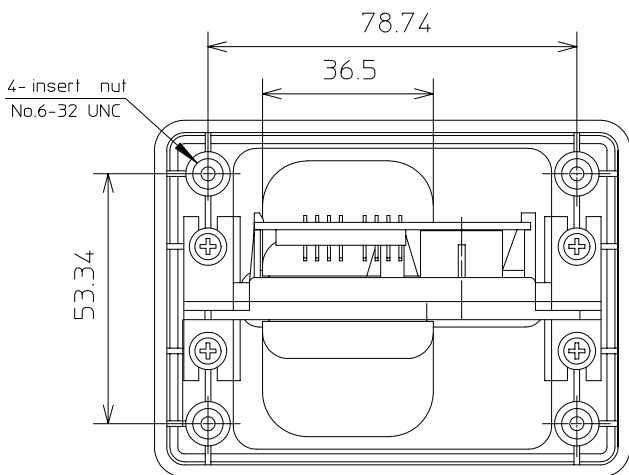

unit:mm